

MODEL : PLUS CYLINDER

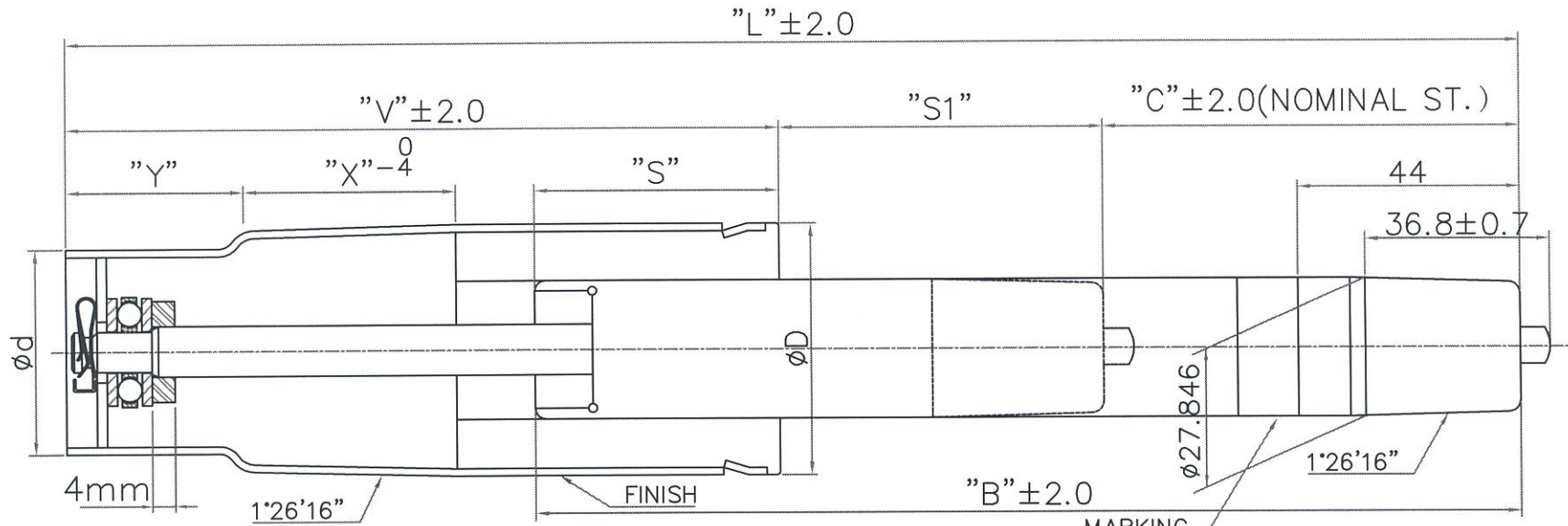

MARKING

 MADE BY KGS CO.,LTD. 0805A
 DON'T OPEN OR HEAT! HIGH PRESSURE!
 TYPE KGL DIN 4550 KLASSE 3. TUV. LGA
 BS 5459 LEVEL 'S'

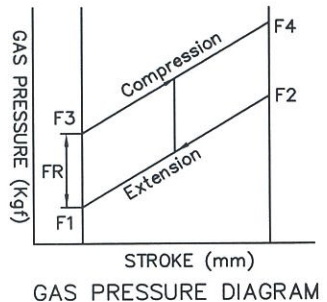

NOTES

1. GAS PRESSURE F1= 30 Kgf $\begin{matrix} +4\text{kgf} \\ -2\text{kgf} \end{matrix}$, FR MAX=8Kgf
2. CAN FINISH : BLACK PAINTING .
3. OUTER PIPE : HARD CHROME PLATING (2.5T).

REV	DATE	DESCRIPTION	DESIGNED	CHECKED	APPROVED	
△	200 . . .					
△	200 . . .					
NO	PART NO.	PART NAME	Q'TY	MATERIAL	REMARKS	
APPROVED		TITLE : ALPHA CYLINDER (ICF)				
CHECKED		 Korea Gas Spring CO.,LTD.				
DESIGNED						
DATE	2008.05.03	TOL	$\begin{matrix} x = \pm 0.5 \\ xx = \pm 0.1 \end{matrix}$	SCALE	N/S	DRAW-NO

NO	BUYER CODE	MODEL NO.	"L"	"C"	"B"	"V"	"X"	"Y"	∅D	∅d	"S"	"S1"	F1(N)	FINISH
1	019-091	KGP3147-5030C1764	419	143	263.5	215	58	48	∅50	∅40	59.5	60	300	BLACK