

MODEL : GAS LIFT  
 SAMPLE NUMBER : KGL4125-5035C6474  
 BUYER CODE.: GASHS215CL

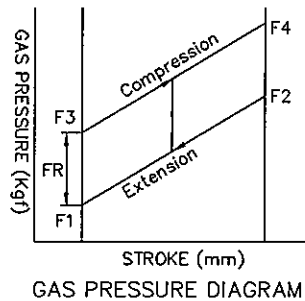
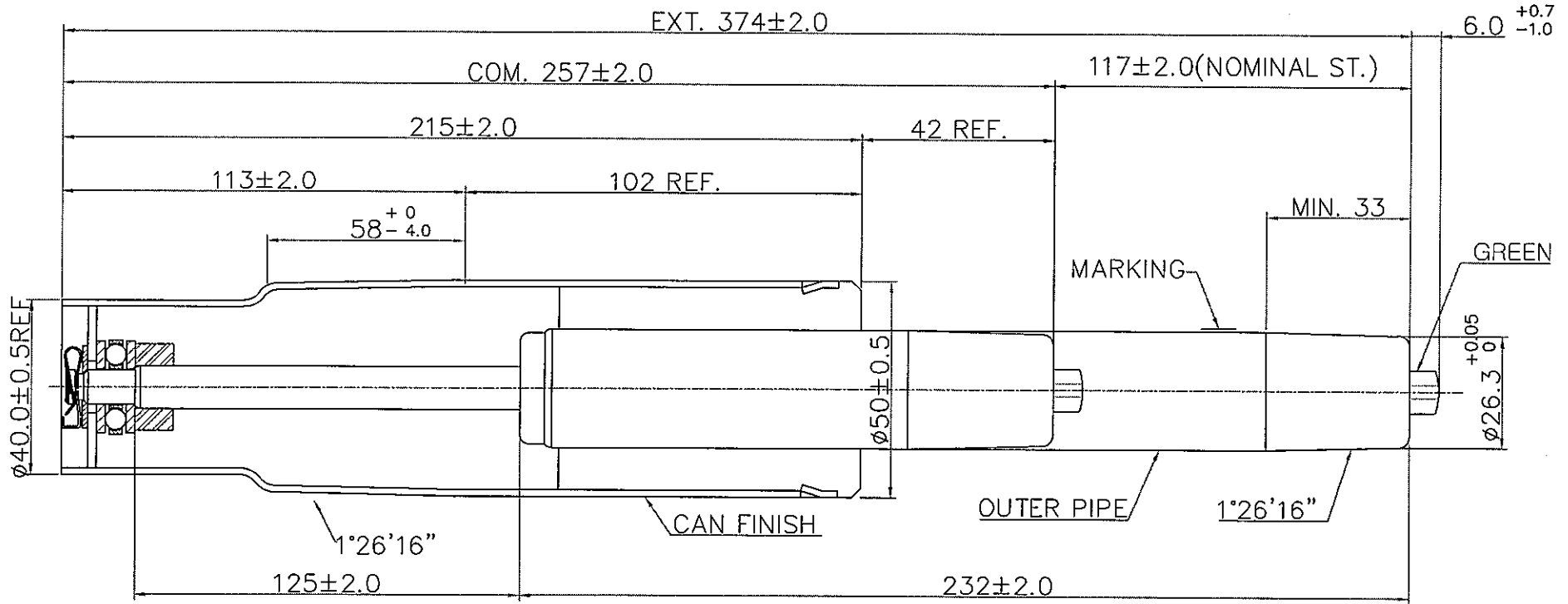

MARKING SPEC

41/16  
 MADE BY KGS CO.,LTD  
 DON'T OPEN OR HEAT! HIGH PRESSURE!  
 TYPE KGL DIN 4550 KLASSE 4.

NOTES

- 1.GAS PRESSURE F1= 35 Kg<sup>f</sup> ±2Kg<sup>f</sup>, FR MAX=8Kg<sup>f</sup>
- 2 CAN FINISH : BLACK PAINTING ( Ø50 X 1.5T ) 114B-125018
3. OUTER PIPE : BLACK HEAT TREATMENT ( 2.0T)

REV	DATE	DESCRIPTION	DESIGNED	CHECKED	APPROVED
△ 201					
△ 201					
NO	PART NO.	PART NAME	Q'TY	MATERIAL	REMARKS
APPROVED		TITLE : GAS LIFT			
CHECKED		Korea Gas Spring CO.,LTD.			
DESIGNED					
DATE	2016.10.08	TOL	X = ±0.5 XX = ±0.1	SCALE	N/S DRAW-NO