

MODEL : GAS LIFT

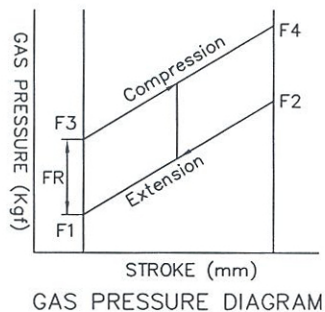
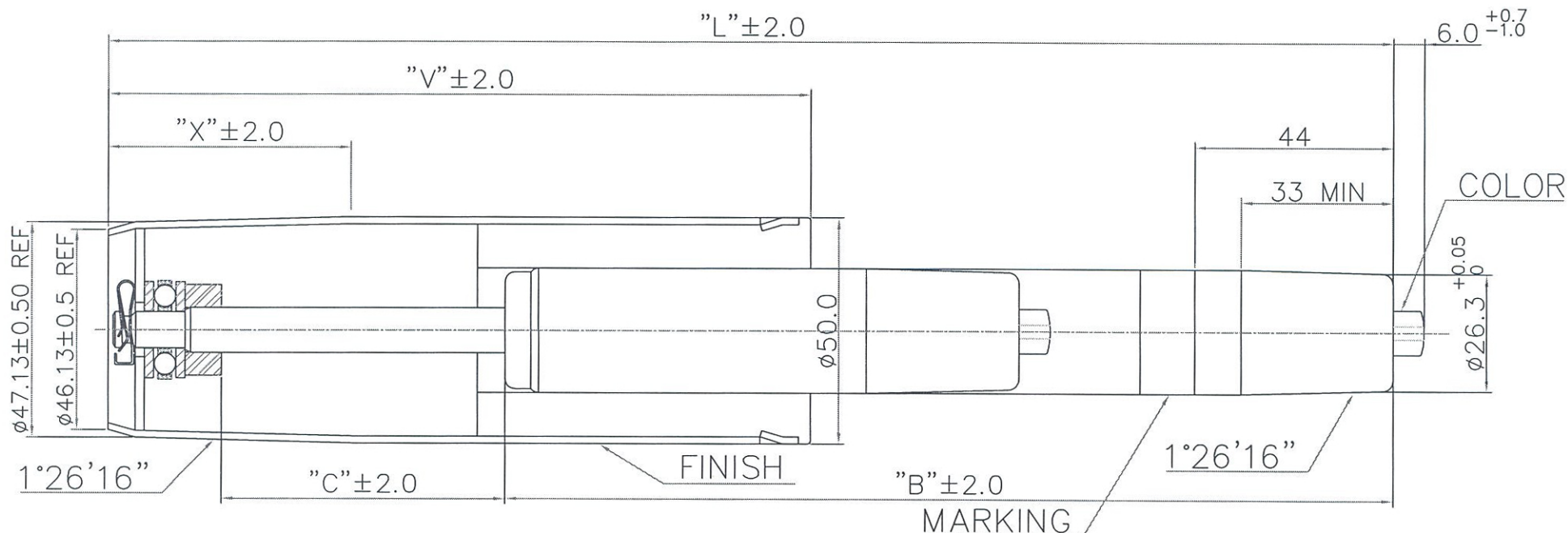

0610B
 MADE BY KGS CO.,LTD
 DON'T OPEN OR HEAT! HIGH PRESSURE!
 TYPE KGL DIN 4550 KLASSE 3. TÜV
 BS 5459 LEVEL 'S'

- NOTES
1. GAS PRESSURE F1= 30 Kgf $\begin{matrix} +4Kgf \\ -2Kgf \end{matrix}$, FR MAX=8Kgf
 2. CAN FINISH : CHROME PLATING.
 3. OUTER PIPE : HARD CHROME PLATING (2.0T).

REV	DATE	DESCRIPTION	DESIGNED	CHECKED	APPROVED
△	200 . .				
△	200 . .				

NO	BUYER CODE	MODEL NO.	"L"	"C"	"B"	"V"	"X"	F1(N)	COLOR	FINISH
1	COD.01	KGL1170-5030C786	544	162	357	318	65	300	BLACK	CHROME

NO	PART NO.	PART NAME	Q'TY	MATERIAL	REMARKS
APPROVED		TITLE : GAS LIFT (MD: ARTECNO)			
CHECKED		Korea Gas Spring CO.,LTD.			
DESIGNED					
DATE	2006.10.27	TOL	X = ±0.5 XX = ±0.1	SCALE	N/S DRAW-NO